

Instructions for wear checks of play equipment

The equipment must be checked for correct operation and safety, especially the points listed below:

Proof of maintenance

Playground

Date of installation

Checks depend on the type of equipment. Any equipment with moving parts must be checked at least twice a year, static equipment at least once a year.

Intervals for maintenance work and checks generally depend on

- location
- kind of use
- frequency of use
- possible vandalism

For more details see also "General instructions for maintenance of playgrounds".

Big Bucket Wheel Order No. 5.159205/5.15925

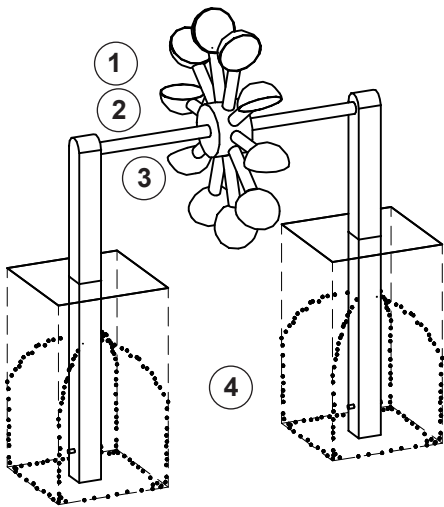

detailed diagram



Bucket wheel

1. Check that the axle is stable; if necessary tighten locking bolts with a 6 mm allen key (see detailed diagram).

Axle

2. Check that the axle moves freely in the bearing block (4 maintenance-free bearings).

Suspension

3. Check that the suspension rod moves freely and without tension. Check that the cotter pins are present.

Structural stability

4. Check the structural stability of the supporting posts once a year (the foundation of the equipment is dependent on the local installation situation).

Note

In the case of damage to the bearings, remove the axle and replace the bearing before the sleeves are worn, if necessary send for repair. Costs will depend on the condition.

To remove the axle, grind off the rivets of the cotter pins on one side of each. Remove cotter pins. Push the axle into one foot and pull out at a slight angle in the opposite direction.

Special notes, e.g. for repairs

Repair not carried out, it is still possible to play on equipment

Repair not carried out, equipment is taken out of action

All work carried out, everything is in order

Maintenance carried out by:

..... Date