



Order No. 5.15920 Big Bucket Wheel

Play value

Metal Bucket Wheels are an eye-catcher in water play areas, particularly when reflections of sparkling light emphasise the delightful design. The small bowls, arranged in a radial shape, are very attractive for children. When the wheel starts turning by the power of water, the child at the pump is working more intensively in order to accelerate the movement of the wheel. The Large Bucket Wheel can also be driven by a stream of water in a channel (see installation situation on the back).

Fundamental characteristics

- High-quality design
- Incentive for playing: small buckets arranged in radial shape

Recommended for

- Supervised play areas, such as kindergartens, schools, after-school programmes or similar
- Public play areas without supervision, such as playgrounds, parks or similar

Barrier-free

- Independent play



Order No. 5.15910 Small Bucket Wheel for site foundations, Photo © Daniel Perales

Small Bucket Wheel for concrete base
Small Bucket Wheel for site foundations
Big Bucket Wheel

Components

1 Part each

Fitting base pipe made of concrete C40/50 for **Order No. 5.15900**, see **Order No. 5.15950** in the price list



Order No. 5.15910 Small Bucket Wheel for site foundations, Photo © Paul Upward

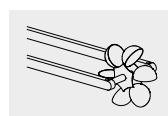

5.15900



5.15910

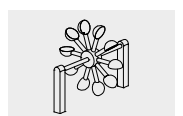

5.15920

Order No. 5.15900
Small Bucket Wheel for concrete base

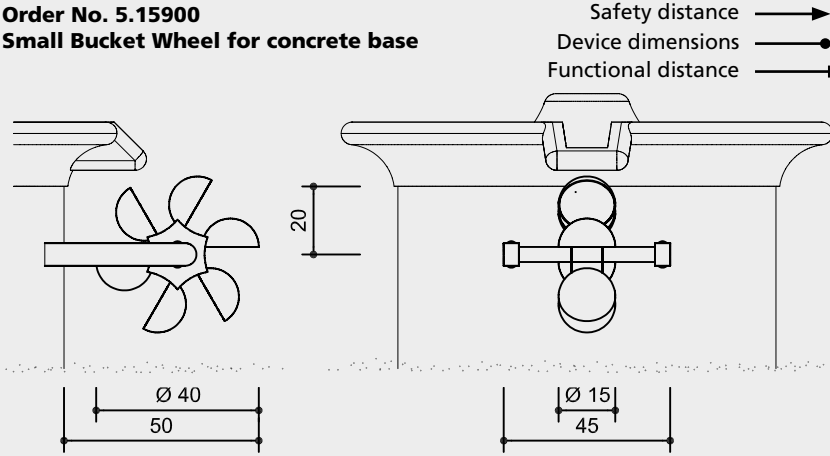

Order No. 5.15910 Small Bucket Wheel for site foundations

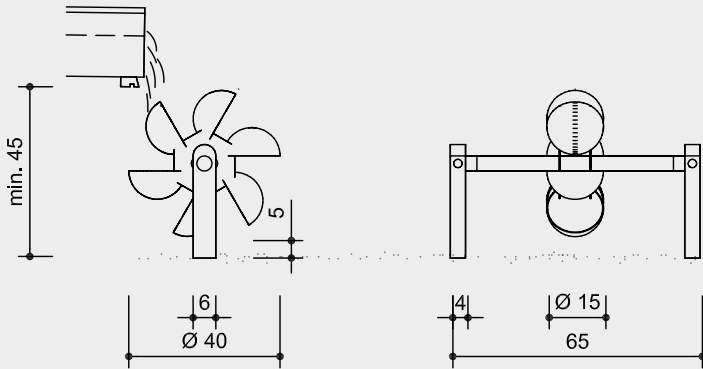

Order No. 5.15920 Big Bucket Wheel

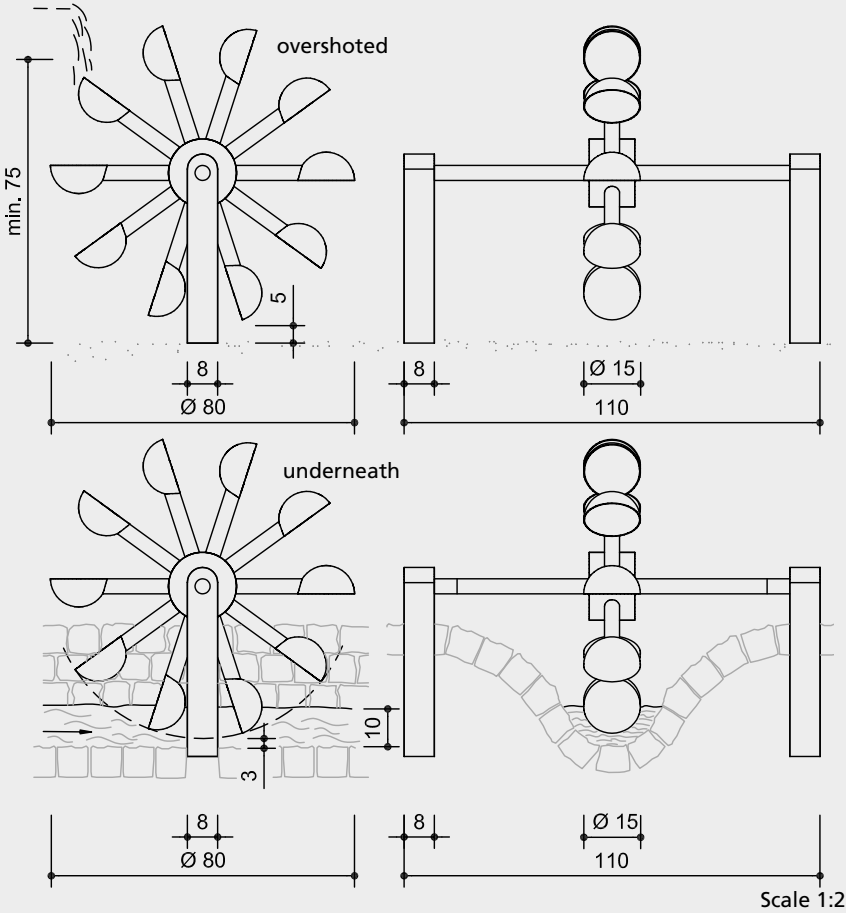

Safety check according to DIN EN 1176

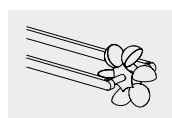

5.15900

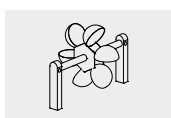

5.15910

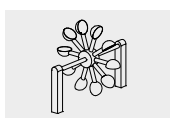

5.15920

Technical information

Equipment made of stainless steel
 glass bead blasted
 thickness of metal sheet 3 mm
 diameter of hemisphere 150 mm

Roller bearings

High-quality roller bearings made of chrome steel or stainless steel for rotating elements, easy to maintain and exchange, sealed



For more detailed explanation of the quality characteristics see price list.

Dimensions

(small deviations possible)

Order No. 5.15900

Small Bucket Wheel for concrete base

Width 0.45 m
 Projection over concrete base 0.50 m
 Diameter of wheel 0.40 m
 Weight 13 kg

Order No. 5.15910 Small Bucket Wheel for site foundations

Height 0.45 m
 Width 0.65 m
 Diameter of wheel 0.40 m
 Weight 13 kg

Order No. 5.15920 Big Bucket Wheel

Height 0.85 m
 Width 1.10 m
 Diameter of wheel 0.80 m
 Weight 22 kg

Installation information

Surfacing requirements

Recommendation: Sand with drainage or paving with gully and appropriate terrain design.

Bucket wheels run better in top-slung operation (water flows onto the buckets from above). Less water is required, but more height difference.

In undershot operation (water flows through the bottom as shown), care must be taken to bring the paving as close as possible to the blades without creating pinch points for fingers. More and faster flowing water is required. This can be dammed up for this purpose e.g. with the draw weir, **Order no. 5.20930** just above the water wheel and then released with momentum. We recommend that the correct installation position be determined in a trial with water before final fixing.

With the small paddle wheel, undershot operation is not possible.

Foundations

Order No. 5.15910

1 item 50 x 90 x 30 cm
 Excavation depth 70 cm

Order No. 5.15920

2 items 40 x 40 x 30 cm
 Excavation depth 70 cm
 (or corresponding installation situation)

Attention:

Exact measurements may vary; for all installation dimensions refer to current assembly instructions.

Technical changes reserved.

For use in aggressive environments such as salt or chlorine water, the equipment is also available in marine grade steel (V4A).