

Play value

The Swinging Horse makes a swinging and rocking movement possible for little ones. Through the strength of the rider a harmonious rocking cycle results which cannot be compared to ordinary upward and downward movement.



Fundamental characteristics

- Child proportions according to ergonomic requirements
- Natural wooden surface which appeals to the senses
- Defined swinging direction through leaf spring, no turning movement
- Incentive for playing: horse body
- Movement: riding, moving one's centre of gravity

Recommended for

- Children under 3 years
- Kindergarten children
- Supervised play areas, such as kindergartens, schools, after-school programmes or similar
- Public play areas without supervision, such as playgrounds, parks or similar

Swinging Horse



4.24150

Order No. 4.24150
Swinging Horse

Safety distance →
Device dimensions —●—
Functional distance —|—

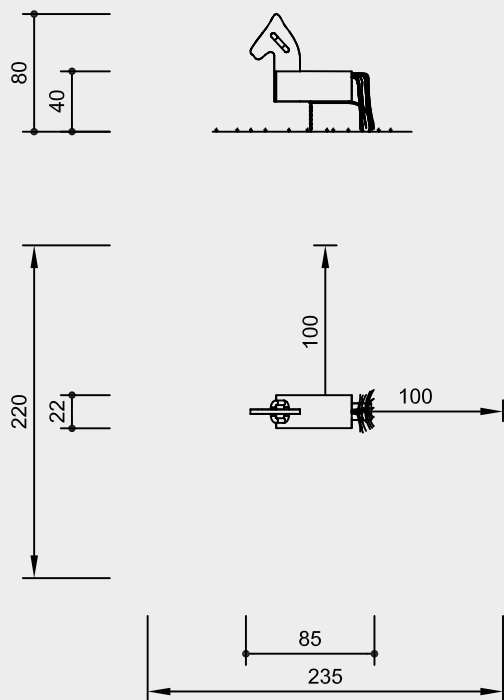

Scale 1:50

Safety check according to DIN EN 1176

Components

1 Horse body,
mounted on leaf spring

Pre-fabricated foundation made of reinforced concrete C35/45 available, see **Order No. 4.24160** in the price list.

Installation information

Surfacing requirements
As for critical fall height ≤ 1.00 m (please refer to price list for more detailed information)

Foundations
1 item 30 x 50 x 20 cm
Excavation depth 30 cm

Note

Loose fall protection material is not suitable for installation with pre-fabricated foundation.

When installing in solid, closed fall protection floors (e.g. EPDM), ensure that the spring can move freely where it exits the floor (otherwise it may break!).

Attention:

Exact measurements may vary; for all installation dimensions refer to current assembly instructions.
Technical changes reserved.

Technical information

Equipment made of not impregnated mountain larch

Peeled white

Palisades peeled white means that bark, cambium and sapwood are removed, the natural shape of the trunk is preserved and can be experienced



Plywood

Plywood made of mountain larch, three-layer (3 cm) or five-layer (4 cm). High dimensional stability, waterproof, glued according to DIN EN 13353:2011



Ground anchor

All parts used for anchoring to the ground are made of hot-dip galvanised steel or stainless steel



Stainless Chains

Chains made of steel with high corrosion resistance. Short-linked, without eyelets on the connecting parts, easily replaceable and simple shortening



Relief cut

Targeted relief cut as an effective measure against cracks caused by drying. The cut defines the position of the stress equalization in the trunk and minimises natural cracking



For more detailed explanation of the quality characteristics see price list.

Leaf spring sand-blasted, hardened and plastic coated

Grips made of polyamide

Tail made of PP rope, 16 mm, 3 strands, weather-resistant, standard colour: natural

Dimensions

(small deviations possible)

Total height	0.80 m
Height seat	0.40 m
Length	0.85 m
Width	0.22 m
Leaf spring	100 x 8 mm
Weight	25 kg



4.24150